

GATE ALARM Installation Instructions

MODEL — GAPT



IMPORTANT

READ THOROUGHLY BEFORE USING ALARM

This product has been designed to aid in the detection of unwanted intrusions into unsupervised areas. POOLGUARD GAPT IS A SAFETY ALARM SYSTEM AND NOT A LIFESAVING DEVICE. It should be used in conjunction with the safety equipment currently in use and should not affect existing safety procedures.

1. INSTALLING GATE SENSOR
(Figure 1)

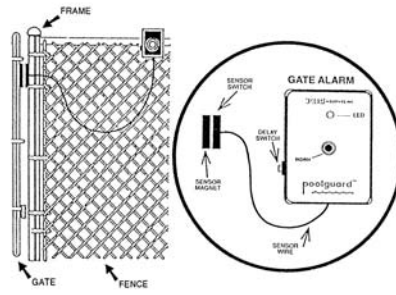
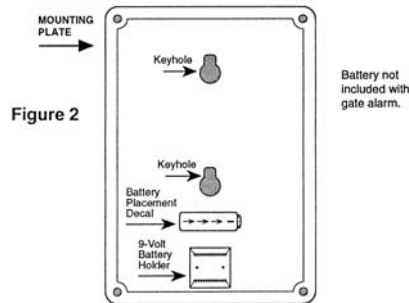

Figure 1

The Poolguard Gate Alarm is activated by a sensor which consists of two parts. One part contains the sensor switch and the other contains the sensor magnet. The sensor switch is permanently connected to the sensing wire that comes from the Poolguard Gate Alarm. Using the screws supplied, the sensor switch is installed on the stationary part (usually the frame) of the fence, and the sensor magnet on the gate itself. The sensor switch should be mounted on the side near the top of the fence post (Figure 1), but not on the side which is hinged. To function properly the sensor switch and sensor magnet should line up with each other, and a spacing of 2 1/2" between the sensor switch and the sensor magnet is acceptable. If either the gate or the fence post is made of steel this may limit the spacing between the sensor switch and sensor magnet to 1 1/4", test your alarm. If a spacing of 2 1/2" is needed, use 1/4" thick wood or plastic shims under the sensor switch and sensor magnet.

2. INSTALLING POOLGUARD GATE ALARM AND BATTERY (Figure 2)

- A. Determine the best location, the gate alarm should be mounted at least 54" high or out of easy reach of a child.
- B. There are many ways of mounting your gate alarm, one of the simplest is explained below. This way will work best for most fences. If you have a chain link fence mounting to a post or piece of wood added to the fence works well.
- C. Remove mounting plate from gate alarm by removing the four small screws.
- D. Place mounting plate at the location which you have chosen to locate the alarm. With a pencil mark the two spots where the large end of the keyholes will be located when you hang the gate alarm. These two marks are where 2 of 6 supplied screws will be inserted to hang your alarm.
- E. Insert the supplied screws, and leave about 3/16" (not including the head of the screw) of the screws.
- F. Connect a 9-volt battery to the battery snap and install the battery into the gate alarm battery holder. See Figure 2 for proper battery placement. Replace the mounting plate and the four screws to hold it in place.
- G. When the 9-volt battery is installed to the gate alarm, the LED will flash once every 10 seconds. When the alarm sounds, the LED will flash once every second.
- H. Hang gate alarm on the mounted screws and pull downward until the screws are positioned in the small end of the keyholes in the back of the unit.



3. OPERATING YOUR GATE ALARM (Figure 1)

The POOLGUARD GATE ALARM uses two delay modes which allows the user to exit and enter the gate without the alarm sounding. These two modes are explained below:

- A. **FIRST DELAY MODE:** When the gate is opened the alarm automatically goes into the first delay mode which gives you 7 seconds after the gate is opened to push the delay switch. If the delay switch is not pushed within 7 seconds the alarm will sound with the gate open or closed. To silence the alarm close the gate then push the delay switch.
- B. **SECOND DELAY MODE:** When the gate is opened and the delay switch is pushed within 7 seconds this puts the gate alarm in the second delay mode which allows you another 7 seconds to go through the gate and close it. When the gate is closed within 7 seconds the alarm will automatically reset. If the gate is not closed within 7 seconds the alarm will automatically go to the first delay mode, then the alarm will sound when the gate is opened or closed.

4. LOW BATTERY FUNCTION

When the 9-volt battery is low, the gate alarm horn will chirp once every 10 seconds—this means it is time to install a new battery. Test your gate alarm weekly by opening the gate and allowing the alarm to sound.

WARRANTY AND REPAIRS

POOLGUARD is sold with a limited warranty to cover defects in parts and workmanship for one year from date of purchase. (Retain proof of purchase). If Poolguard exhibits a defect, please call our Customer Service department at 1-800-242-7163. Unauthorized returns will not be accepted. Proper repair is only ensured when the unit is returned to the manufacturer.

PBM INDUSTRIES, INC.

P.O. Box 658
NORTH VERNON, IN 47265
812-346-2648



PBM INDUSTRIES, INC.
MADE IN THE USA